

Features

- 1.4V Maximum Dropout at Full Load Current
- Built-in Thermal Shutdown
- Output Current Limiting
- Adjustable Output Voltage or Fixed 1.5V, 1.8V, 2.5V, 3.3V, 5.0V
- Fast Transient Response
- Good Noise Rejection
- Lead Free Packages: TO252-3L, TO263-3L and TO220-3L (Note 1)
- TO252-3L: Available in "Green" Molding Compound (No Br, Sb)
- Lead Free Finish/RoHS Compliant (Note 2)

General Description

AP1084 is a low dropout positive adjustable or fixed-mode regulator with 5.0A output current capability. The product is specifically designed to provide well-regulated supply for low voltage IC applications such as high-speed bus termination and low current 3.3V logic supply. AP1084 is also well suited for other applications such as VGA cards. AP1084 is guaranteed to have lower than 1.4V dropout at full load current making it ideal to provide well-regulated outputs of 1.25 to 3.3V with 4.7 to 12V input supply.

Ordering Information

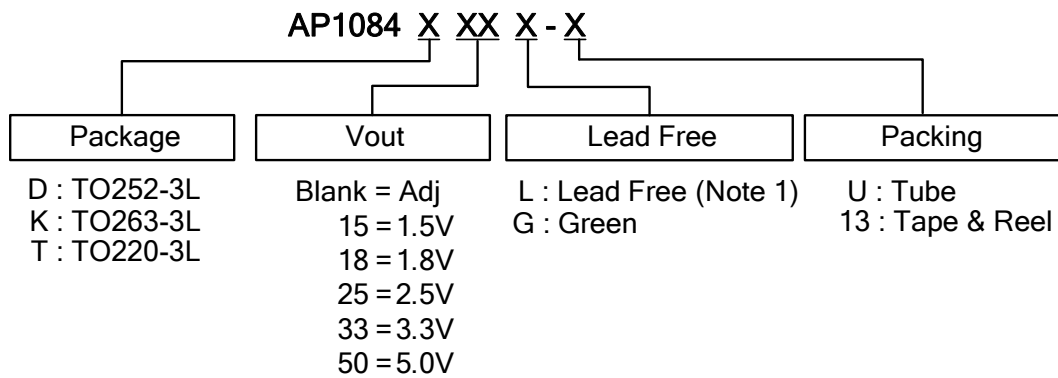

Device	Package Code	Packaging (Note 3)	Tube/Bulk		13" Tape and Reel	
			Quantity	Part Number Suffix	Quantity	Part Number Suffix
AP1084DXXL-U	D	TO252-3L	80	-U	NA	NA
AP1084DXXL-13	D	TO252-3L	NA	NA	2500/Tape & Reel	-13
AP1084DXXG-U	D	TO252-3L	80	-U	NA	NA
AP1084DXXG-13	D	TO252-3L	NA	NA	2500/Tape & Reel	-13
AP1084KXXL-U	K	TO263-3L	50	-U	NA	NA
AP1084KXXL-13	K	TO263-3L	NA	NA	800/Tape & Reel	-13
AP1084TXXL-U	T	TO220-3L	50	-U	NA	NA

- Notes:
1. TO263-3L and TO220-3L are available in "Lead Free" products only.
 2. EU Directive 2002/95/EC (RoHS). All applicable RoHS exemptions applied, see *EU Directive 2002/95/EC Annex Notes*.
 3. Pad layout as shown on Diodes Inc. suggested pad layout document AP02001, which can be found on our website at <http://www.diodes.com/datasheets/ap02001.pdf>.

Pin Assignment

(1) TO252-3L

(Top View)

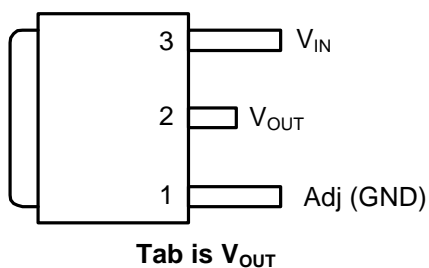

(2) TO263-3L

(Top View)

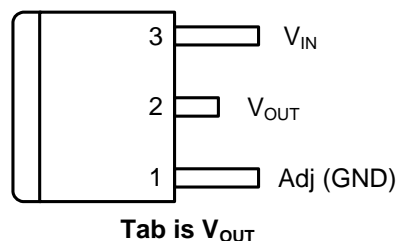

(3) TO220-3L

(Top View)

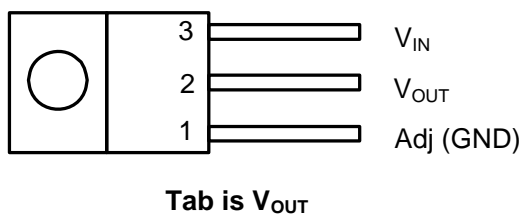

Pin Description

Pin Name	I/O	Pin #	Description
Adj (GND)	I	1	Adjustable (Ground only for fixed mode) A resistor divider from this pin to the V_{OUT} pin and ground sets the output voltage (Ground only for Fixed-Mode).
V_{OUT}	O	2	The output of the regulator. A minimum of 10 μ F ($0.15\Omega \leq ESR \leq 20\Omega$) capacitor must be connected from this pin to ground to insure stability.
V_{IN}	I	3	The input pin of regulator. Typically a large storage capacitor ($0.15\Omega \leq ESR \leq 20\Omega$) is connected from this pin to ground to insure that the input voltage does not sag below the minimum dropout voltage during the load transient response. This pin must always be 1.4V (1.3V) higher than V_{OUT} in order for the device to regulate properly.

Block Diagram

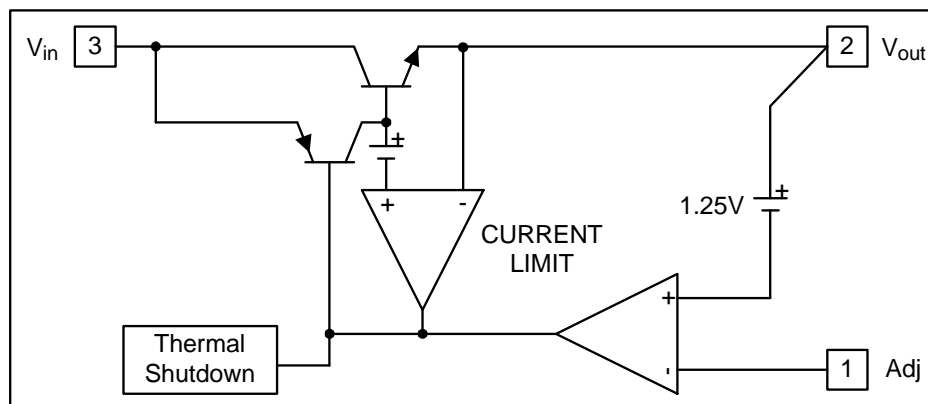

Absolute Maximum Ratings

Symbol	Parameter	Rating	Unit
V_{IN}	DC Supply Voltage	-0.3 to 12	V
T_{ST}	Storage Temperature	-65 to +150	°C
T_M	Maximum Junction Temperature	150	°C

Recommended Operating Conditions

Symbol	Parameter	Rating	Unit
T_J	Operating Junction Temperature Range	-40~125	°C

Electrical Characteristics (Under Operating Conditions)

Symbol	Parameter	Conditions	Min	Typ.	Max	Unit
V_{REF}	Reference Voltage	$I_o = 10\text{mA}$, $T_A = 25^\circ\text{C}$, $(V_{IN}-V_{OUT}) = 1.5\text{V}$	1.225	1.250	1.275	V
Line Regulation	AP1084-XXX	$I_o = 10\text{mA}$, $V_{OUT}+1.5\text{V}<V_{IN}<12\text{V}$, $T_A = 25^\circ\text{C}$			0.2	%
	AP1084-1.5	$I_{OUT} = 10\text{mA}$, $T_A = 25^\circ\text{C}$, $3\text{V} \leq V_{IN} \leq 12\text{V}$	1.470	1.500	1.530	V
	AP1084-1.8	$I_{OUT} = 10\text{mA}$, $T_A = 25^\circ\text{C}$, $3.3\text{V} \leq V_{IN} \leq 12\text{V}$	1.764	1.800	1.836	V
	AP1084-2.5	$I_{OUT} = 10\text{mA}$, $T_A = 25^\circ\text{C}$, $4\text{V} \leq V_{IN} \leq 12\text{V}$	2.450	2.500	2.550	V
	AP1084-3.3	$I_{OUT} = 10\text{mA}$, $T_A = 25^\circ\text{C}$, $4.8\text{V} \leq V_{IN} \leq 12\text{V}$	3.235	3.300	3.365	V
	AP1084-5.0	$I_{OUT} = 10\text{mA}$, $T_A = 25^\circ\text{C}$, $6.5\text{V} \leq V_{IN} \leq 12\text{V}$	4.900	5.000	5.100	V
Load Regulation	AP1084-Adj	$V_{IN} = 3.3\text{V}$, $0\text{mA} < I_o < 5\text{A}$, $T_A = 25^\circ\text{C}$			1	%
	AP1084-1.5	$V_{IN} = 3\text{V}$, $0\text{mA} < I_o < 5\text{A}$, $T_A = 25^\circ\text{C}$ (Note 4, 5)		12	15	mV
	AP1084-1.8	$V_{IN} = 3.3\text{V}$, $0\text{mA} < I_o < 5\text{A}$ $T_A = 25^\circ\text{C}$ (Note 4, 5)		15	18	mV
	AP1084-2.5	$V_{IN} = 4\text{V}$, $0\text{mA} < I_o < 5\text{A}$ $T_A = 25^\circ\text{C}$ (Note 4, 5)		20	25	mV
	AP1084-3.3	$V_{IN} = 5\text{V}$, $0\text{mA} < I_o < 5\text{A}$, $T_A = 25^\circ\text{C}$ (Note 4, 5)		26	33	mV
	AP1084-5.0	$V_{IN} = 8\text{V}$, $0\text{mA} < I_o < 5\text{A}$, $T_A = 25^\circ\text{C}$ (Note 4, 5)		40	50	mV
ΔV_o	Dropout Voltage	$I_o = 5.0\text{A}$ ($\Delta V_{OUT} = 1\% V_{OUT}$)		1.3	1.4	V
	Current Limit	$V_{IN}-V_{OUT} = 5\text{V}$	5.1			A
	Minimum Load Current			5	10	mA
	Temperature Stability	$I_o = 10\text{mA}$		0.5		%
T_{SD}	Thermal Shutdown Temperature			150		$^\circ\text{C}$
θ_{JA}	Thermal Resistance Junction-to-Ambient (Note 6)	TO220-3L		78		$^\circ\text{C/W}$
		TO252-3L		73		
		TO263-3L		60		
θ_{JC}	Thermal Resistance Junction-to-Case (Note 6)	TO220-3L:Control Circuitry/Power Transistor		3.5		$^\circ\text{C/W}$
		TO252-3L:Control Circuitry/Power Transistor		12		
		TO263-3L:Control Circuitry/Power Transistor		3.5		

- Notes: 4. See thermal regulation specifications for changes in output voltage due to heating effects. Line and load regulation are measured at a constant junction temperature by low duty cycle pulse testing. Load regulation is measured at the output lead = 1/18" from the package.
5. Line and load regulation are guaranteed up to the maximum power dissipation of 15W. Power dissipation is determined by the difference between input and output and the output current. Guaranteed maximum power dissipation will not be available over the full input/output range.
6. Test conditions for TO220-3L, TO252-3L and TO263-3L: Devices mounted on FR-4 substrate, single sided PC board, 2oz copper, with minimum recommended pay layout, no air flow.

Typical Circuit

For TO252-3L/ TO263-3L /TO220-3L

5.0V to 3.3V Fixed Mode Regulator

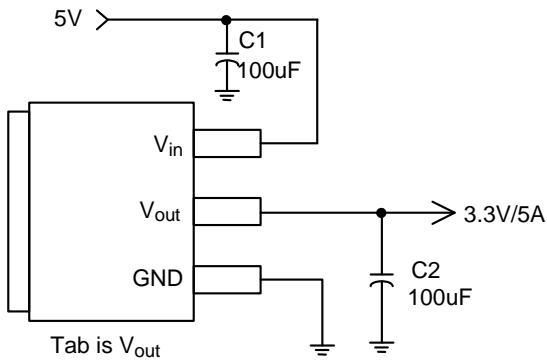

Adjustable Regulator

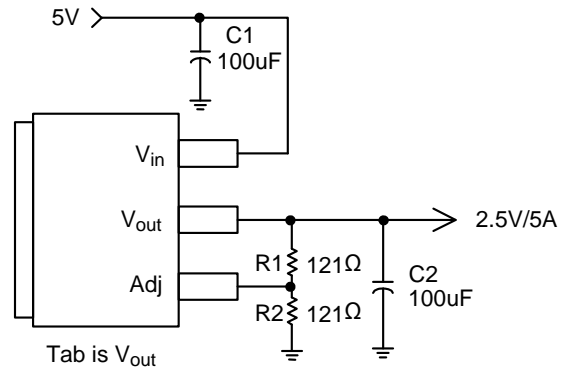

Note: $V_O = V_{REF} * (1 + \frac{R_2}{R_1})$

Functional Description

Introduction

The AP1084 adjustable Low Dropout (LDO) regulator is a 3 terminal device that can easily be programmed with the addition of two external resistors to any voltages within the range of 1.25V to $V_{in}-1.4V$. The AP1084 only needs 1.4V differential between V_{IN} and V_{OUT} to maintain output regulation. In addition, the output voltage tolerances are also extremely tight and they include the transient response as part of the specification. For example, Intel VRE specification calls for a total of +/- 100mV including initial tolerance, load regulation and 0 to 5.0A load step.

The AP1084 is specifically designed to meet the fast current transient needs as well as providing an accurate initial voltage, reducing the overall system cost with the need for fewer output capacitors.

Output Voltage Setting

The AP1084 can be programmed to any voltages in the range of 1.25V to $V_{in}-1.4V$ with the addition of R1 and R2 external resistors according to the following formula:

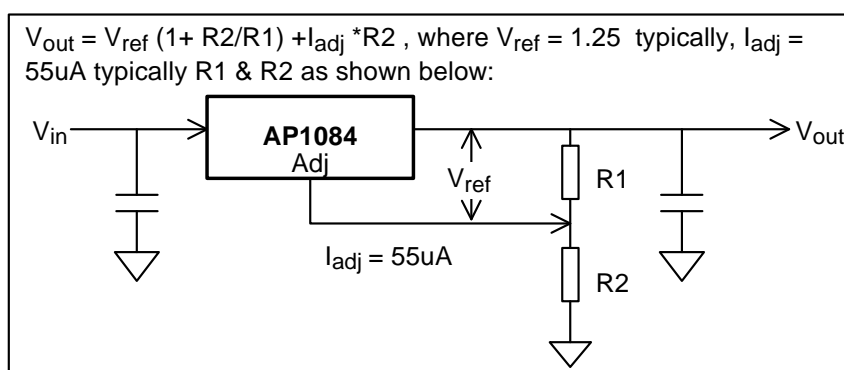

The AP1084 keeps a constant 1.25V between the output pin and the adjust pin. By placing a resistor R1 across these two pins a constant current flows through R1, adding to the I_{adj} current and into the R2 resistor producing a voltage equal to the $(1.25/R1)*R2 + I_{adj}*R2$ which will be added to the 1.25V to set the output voltage. This is summarized in the above equation. Since the minimum load current requirement of the AP1084 is 10mA, R1 is typically selected to be 121Ω resistor so that it automatically satisfies the minimum current requirement. Notice that since I_{adj} is typically in the range of 55uA it only adds a small error to the output voltage and should only be considered when a very precise output voltage setting is required. For example, in a typical 3.3V application where $R1=121\Omega$ and $R2=200\Omega$ the error due to I_{adj} is only 0.3% of the nominal set point.

Load Regulation

Since the AP1084 is only a 3 terminal device, it is not possible to provide true remote sensing of the output voltage at the load. The best load regulation is achieved when the bottom side of R2 is connected to the load and the top-side of R1 resistor is connected directly to the case or the V_{OUT} pin of the regulator and not to the load. It is important to note that for high current applications, this can re-present a significant percentage of the overall load regulation and one must keep the path from the regulator to the load as short as possible to minimize this effect.

Stability

The AP1084 requires the use of an output capacitor as part of the frequency compensation in order to make the regulator stable. For most applications a minimum of 10uF aluminum electrolytic capacitor insures both stability and good transient response.

Thermal Design

The AP1084 incorporates an internal thermal shutdown that protects the device when the junction temperature exceeds the maximum allowable junction temperature. Although this device can operate with junction temperatures in the range of 150°C, it is recommended that the selected heat sink be chosen such that during maximum continuous load operation the junction temperature is kept below that temperature.

Layout Consideration

The output capacitors must be located as close to the V_{OUT} terminal of the device as possible. It is recommended to use a section of a layer of the PC board as a plane to connect the V_{OUT} pin to the output capacitors to prevent any high frequency oscillation that may result due to excessive trace inductance.

Typical Performance Characteristics

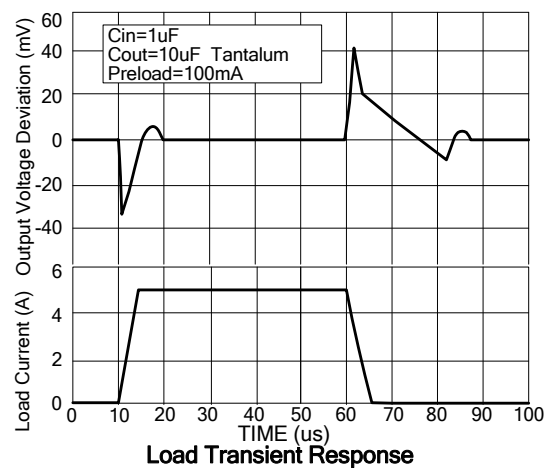
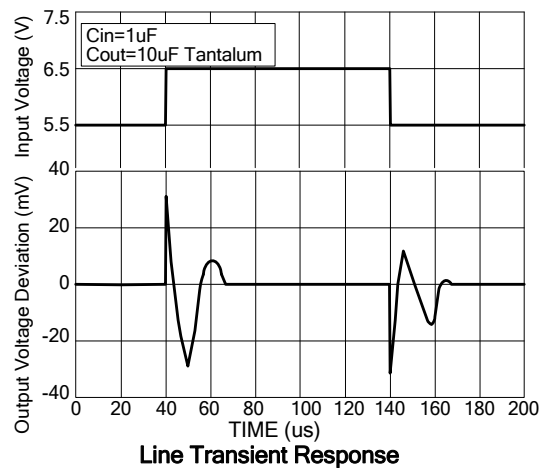
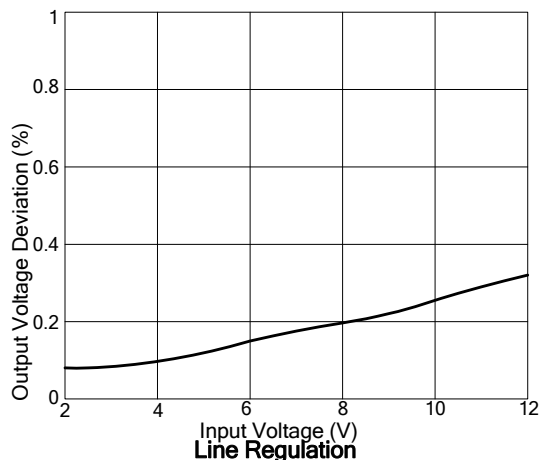
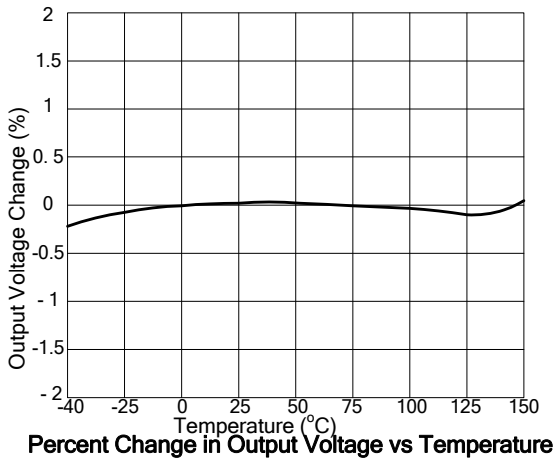
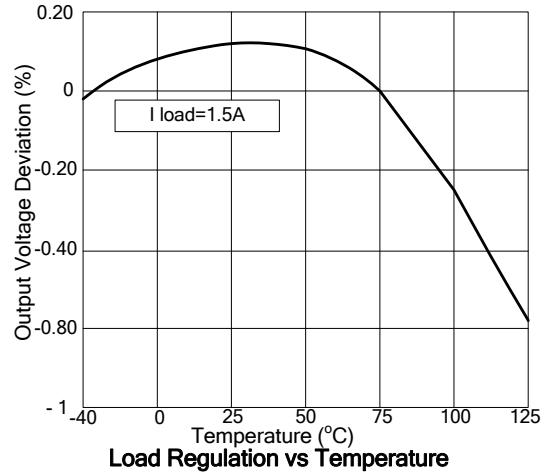
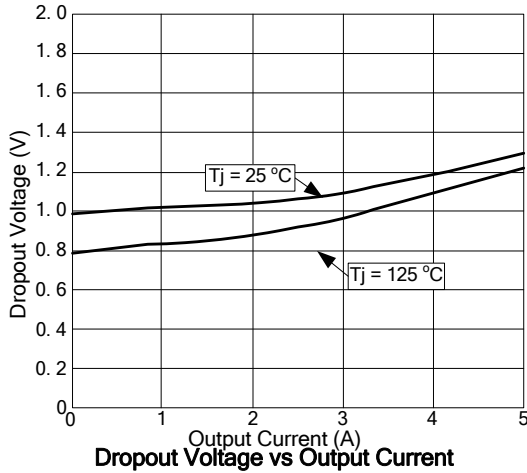

Marking Information

(1) TO252-3L

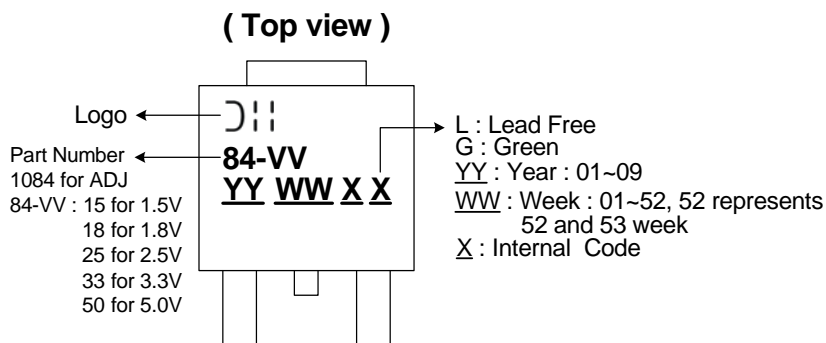

(2) TO263-3L

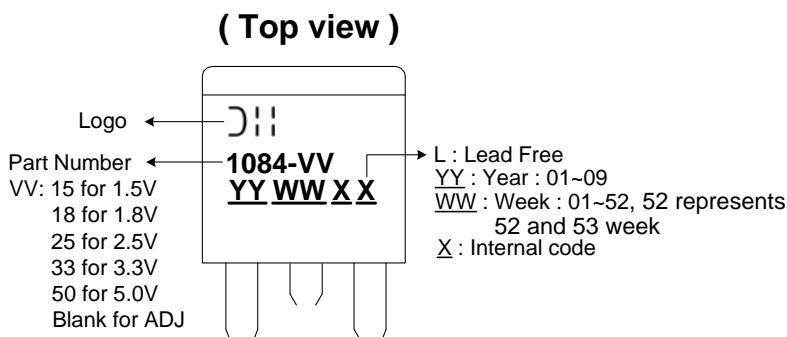

(3) TO220-3L

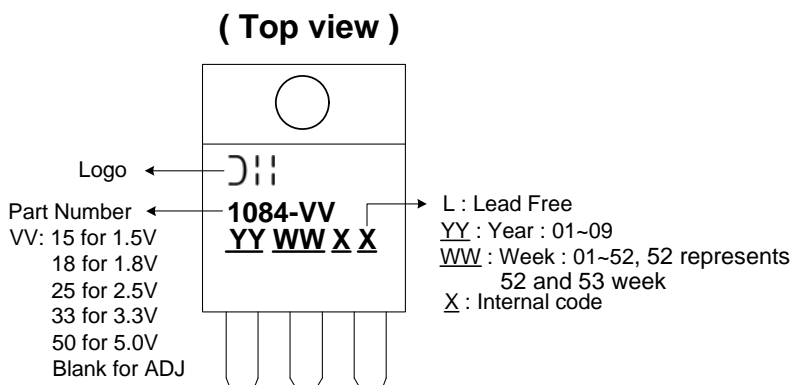

Package Information (All Dimensions in mm)

(1) Package type: TO252-3L

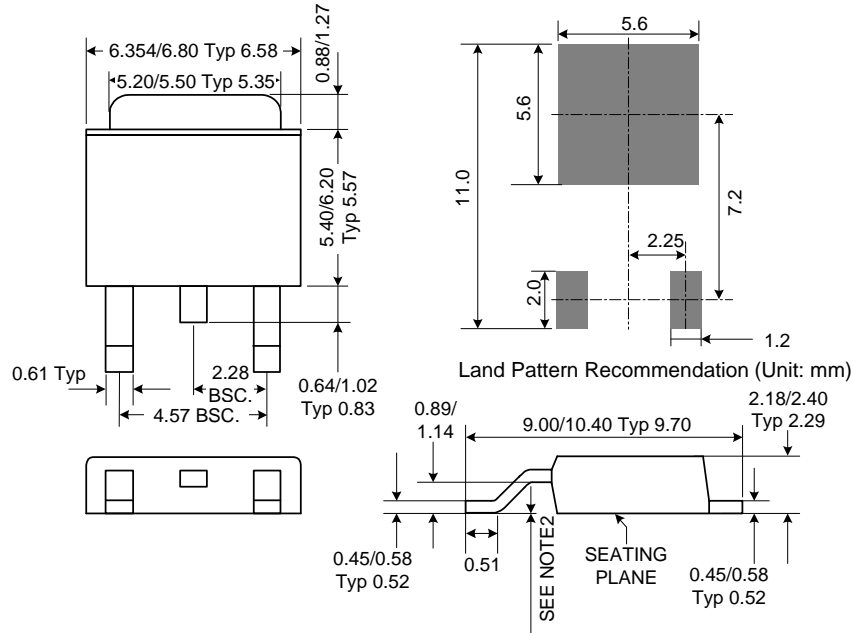

(2) Package type: TO263-3L

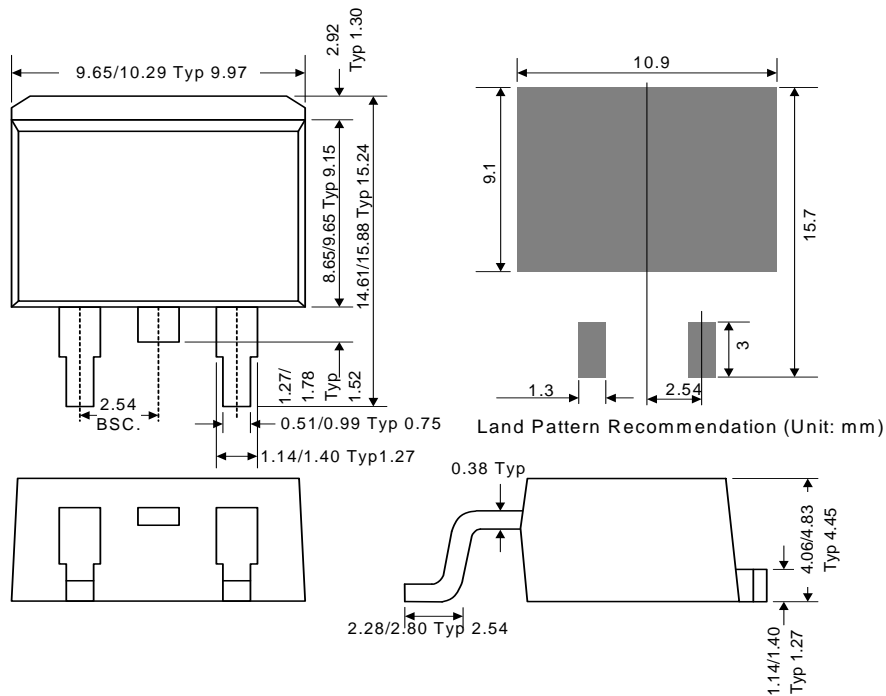

Package Information (Continued)

(3) Package type: TO220-3L

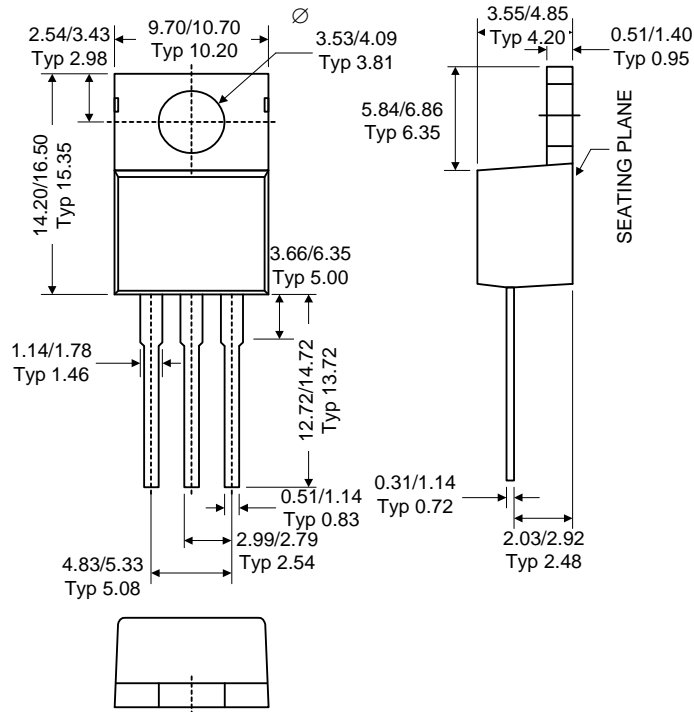

IMPORTANT NOTICE

Diodes Incorporated and its subsidiaries reserve the right to make modifications, enhancements, improvements, corrections or other changes without further notice to any product herein. Diodes Incorporated does not assume any liability arising out of the application or use of any product described herein; neither does it convey any license under its patent rights, nor the rights of others. The user of products in such applications shall assume all risks of such use and will agree to hold Diodes Incorporated and all the companies whose products are represented on our website, harmless against all damages.

LIFE SUPPORT

Diodes Incorporated products are not authorized for use as critical components in life support devices or systems without the expressed written approval of the President of Diodes Incorporated.